



AT220 Ruggedised Tracking Device

User Guide

Version: 3.1

Date: November 2011

Table of Contents

Table of Contents	2
Abbreviations	3
Product Overview	4
Features	4
Technical Specifications	5
Hardware Description	6
Electrical Parameters	10
Configuration	11
Application Parameters	13

Abbreviations

ADC	Analogue to Digital Converter
ASCII	American Standard Code for Information Interchange (computer character set)
ATP	Advanced Telematics Protocol
DC	Direct Current
FET	Field Effect Transistor
GIS	Geographic Information System
GPRS	General Packet Radio Service (part of GSM)
GPS	Global Positioning System
GSM	Global System for Mobile communication
IP	Internet Protocol (part of TCP/IP)
LED	Light Emitting Diode
MEMS	Micro Electro-Mechanical System
NMEA	National Marine Electronics Association (defined a GPS output format)
OTA	Over the Air (remote configuration of devices)
PC	Personal Computer
PCB	Printed Circuit Board
PDU	Protocol Description Unit (describes a binary SMS format)
RFID	Radio Frequency Identification
SIM	Subscriber Identity Module
SMS	Short Message Service
SMSC	Short Message Service Centre
SV	Satellite Vehicle
TCP	Transmission Control Protocol (part of TCP/IP)
UDP	User Datagram Protocol
WGS84	World Geodetic System 1984 (global co-ordinate system used by GPS)

Product Overview

The AT220 is a rugged tracking device, housed in a sturdy plastic enclosure with internal GPS/GSM antennas and sealed to IP67 specifications. The AT220 incorporates the very latest technology, including the latest Cortex M3 ARM processor and state-of-the-art SiRFstar IV GPS with high sensitivity and anti-jamming features. The AT220 operates from an external power feed and has an optional 1700mAh back-up battery which allows operation for over 24 hours in continuous mode. Interconnections are made with a single 8 core cable terminated in an industry standard M12 circular connector.

Features

The main features of the AT220 are highlighted below:

- Compact size (approximately cigarette box dimensions)
- IP67 sealing
- Cortex M3 ARM Processor
- SiRFstar IV GPS, -163dBm sensitivity and anti-jamming feature
- Sagem HiLoNC GSM/GPRS modem
- Internal GSM and GPS antennas
- Low power consumption (near zero current drain when vehicle ignition is off)
- 3 axis accelerometer (2/8g)
- Tremble sensor
- Internal back-up battery, lithium, 1700mAh, 24 hour operation (optional)
- Remote configuration, diagnostics and firmware update
- Supports AT100 Protocol "C" for easy compatibility with existing applications
- Reporting protocols support TCP, UDP and SMS modes
- Pass through data mode
- SDK available for rapid development of client customised applications
- Approved for all markets: CE, 2004/104/EC, FCC, A-tick

AT220B has additional features below:

- 2nd accelerometer (6/12/24g)
- CANBus interface

Technical Specifications¹

E-GSM/GPRS Modem:	2 Watts (E-GSM900 and GSM850 Class 4) 1 Watt (GSM1800 and GSM1900 Class 1) GPRS multi-slot class 10
GSM up-link (TX): Frequencies	824 – 849 MHz, 880 – 915 MHz, 1710 - 1785 MHz, 1850 – 1910 MHz
GSM down-link (RX): Frequencies	869 – 894 MHz, 925 - 960 MHz, 1805 - 1880 MHz, 1930 - 1990 MHz
GPS Receiver:	
L1 receiver:	48 channels
Position accuracy:	< 2.5m CEP autonomous
Receiver sensitivity:	-163dBm (tracking)
TTFF: Cold start	< 35 sec
Warm start	< 32 sec
Hot start	< 1 sec
Input voltage:	8 – 32 volts DC
Input Protection:	Reverse polarity, overvoltage, internal self-resetting fuse
Internal Battery:	3.7V, 1700mAh, lithium (optional)
Battery Life:	18 hours continuous operation 14 days operation in hourly update mode
Data transfer modes:	GPRS (TCP/UDP) SMS PDU
Inputs/outputs:	1 digital input 1 digital output 1 RS232 serial port 1 ADC input (AT220A only) CANBus (AT220B only) iButton (this can alternatively be used as an active low digital input)
Driver ID:	iButton
Current consumption:	25mA @ 13.8 VDC (typical) < 4mA (sleep mode - without battery) < 50uA (sleep mode - battery fitted)
Dimensions:	95 x 65 x 30 mm (3.7" x 2.6" x 1.2")
Weight:	160g (with battery)
Ingress Protection:	IP67 according to DIN VDE 0470 Part 1 / EN 60 529 / IEC 529
Temperature:	
Operating	-40 to +85°C (no battery) -20 to +60°C (with battery)
Storage	-40 to +85°C
Connector:	M12 8 pin male (industry standard IEC 61076-2-101)
Mating Cable Assembly:	Tyco PN 1838344-1 (Straight) or 1838392 (Right Angle)
Product Approvals:	CE, 2004/104/EC, EuP, FCC, PTRCB, A-tick

¹ Specifications may change without notice.

Hardware Description

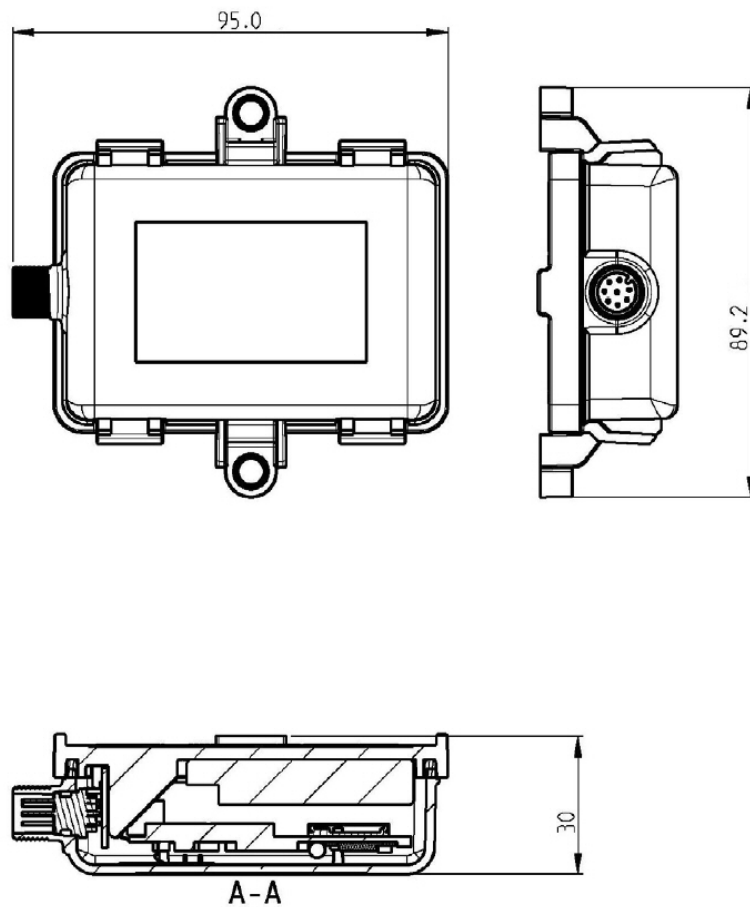

Dimensions
95 x 89 x 30 mm

SIM installation

The AT220 is shipped in open form to allow installation of the SIM card. Care must be taken to avoid any mismatch of the enclosure halves to prevent incorrect association of device IMEI and label.



Enclosure Sealing

When fitting the enclosure cover, please ensure that all 4 clips are snapped into place to guarantee IP67 sealing. A special tool is available to re-open the enclosure, please contact Astra Telematics for details. Attempting to remove the cover without the appropriate tool will be likely to result in breakage of the clips.

Note that the M12 connector only provides IP67 sealing when the connector is mated (i.e. when the cable is attached). If the AT220 is to be used without the cable (running on battery), a suitable sealing cap should be used. When installed in harsh environments, we recommend that the AT220 is fitted with the connector end facing down.

Note also that the enclosure cover holds the PCB extension and M12 connector securely in place. Please do not attempt to connect the M12 cable when the cover is removed.

Power requirements

The AT220 operates from a DC Voltage between 8 and 32 Volts. We recommend that a permanent 'live' power source is used to supply the AT220. If current drain is of concern, please refer to the power management section for options to minimise vehicle battery drain when stationary for long periods.

Back-up Battery (option)

The AT220 operates from the external voltage source. If the optional back-up battery is fitted, the AT220 will maintain optimum charge level and automatically switch to battery power should the external voltage source fail or fall outside of the permitted range. Note that the operating temperature range of the AT220 is reduced when the battery option is fitted (see Specifications section). Please also note the handling precautions for lithium polymer batteries as outlined in the AT220 Installation Guide.

Fuse Recommendations

Typical current drain is 25mA @ 13.8VDC and 14mA @ 27.6VDC, although maximum peak current can be around 1.5A for very short periods. We recommend the use of 3A fuses in the power feeds and ignition sense wires (PINK, RED and GREEN or WHITE wires).

Interconnections

All connections to the AT220 are provided by a single M12 8-way circular IP67 cable assembly. These cables are industry standard (IEC 61076-2-101) and available from a wide variety of suppliers and also available as optional accessories from Astra Telematics. Please refer to our AT220 Price List for details.

Note that the pin applications differ slightly on the AT220A and AT220B. The tables below show the different applications, pins 1 and 7 being dependent on A/B version and all other pins the same.

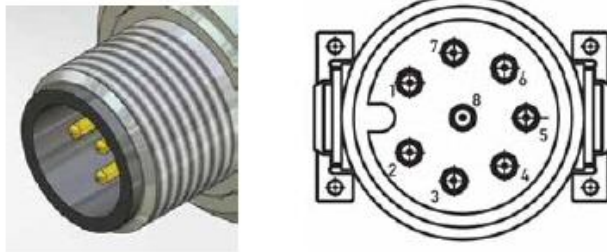

AT220A Pin Applications and Colour Code

Pin Number	Application	Wire Colour
1	Digital input 2	white
2	RS232 RX	brown
3	Digital input 1 (IGN) or Digital Output*	green
4	RS232 TX	yellow
5	iButton (Dallas Key) interface	grey
6	Supply Voltage, 8-32 VDC	pink
7	Digital input / ADC input (user configurable)	blue
8	GND	red

AT220B Pin Applications and Colour Code

Pin Number	Application	Wire Colour
1	CAN-H	white
2	RS232 RX	brown
3	Digital input 1 (IGN) or Digital Output*	green
4	RS232 TX	yellow
5	iButton (Dallas Key) interface	grey
6	Supply Voltage, 8-32 VDC	pink
7	CAN-L	blue
8	GND	red

Digital Inputs

Digital inputs can be connected directly to 12/24V vehicle circuits. Note that CAN-L and CAN-H pins will not withstand continuous 12V levels and damage may occur if used improperly.

Digital Output*

The digital output is a low side MOSFET switch. This shares the same physical input pin as the ignition sense input, Digital 1, and hence can only be used when the ignition input is not being used. If the digital output is required, the use of IGNM mode 3 or 4 is necessary (see IGNM parameter later in this document).

The digital output switch can handle loads of up to 30V, 0.5A maximum. The use of a 3A fuse in-line with the digital output is essential to prevent any damage through fault scenarios.

Analogue to Digital Converter (ADC) Input

The ADC input can be used to measure a voltage range from 0 to 32V.

Integrated Motion/Tremble Sensor

This device allows the AT220 to wake from sleep on movement. Please refer to the Power Management section for more details.

Integrated Accelerometer(s)

The AT220A has a built in 3 axis MEMS accelerometer that operates in the range $\pm 2g$ and is used to measure driver behaviour (acceleration and braking) during normal driving conditions. The AT220B has an additional accelerometer that operates in the range $\pm 12g$ that is used to support collision detection and reporting features.

iButton (Dallas Key) Interface

Both models of AT220 have an interface which can be used to read iButton devices for the purpose of Driver Identification. See the Driver ID Application Note for more details of how to use this feature.

Driver Privacy Mode

The iButton interface can also be used as an active low input. This input has an internal pull-up resistor, so it may be switched to GND for use as a Privacy Mode switch or similar application.

CANBus (option)

The AT220B version has integrated CANBus. Details on supported protocols and features are TBA.

IMPORTANT NOTE: The CANBus pins are ESD protected to 15kV, but can only withstand a continuous voltage of 12V maximum. These pins must not be used for any other application to avoid damage to the device.

Electrical Parameters

Operating Conditions

Parameter	Min	Max	Units
Power Supply Input Voltage	+8	+32	V
Digital Input High Voltage Threshold	+5.0	-	V
Digital Input Low Voltage Threshold	-	+2.0	V
Digital Output Low Voltage, I = 100mA	-	+1.0	V
Digital Output Low Voltage, I = 500mA	-	+2.0	V

Absolute Maximum Ratings

Parameter	Min	Max	Units
Power Supply Input Voltage	-32	+60	V
Voltage on Digital and ADC Inputs	-32	+32	V
Voltage on RS232 RX	-25	+25	V
Voltage on RS232 TX	-13	+13	V
Voltage on CAN RX/TX	-12	+12	V
Voltage on iButton/Dallas Interface	-5	+5	V
Current sunk by digital output (FET switch)		500	mA
Storage Temperature	-40	+85	°C
Operating Temperature (without battery)	-40	+85	°C
Operating Temperature (with battery)	0	45	°C

Typical Power Consumption

Operating Mode	Current @ 13.8V	Current @ 27.6V	Power Consumption
Fully Operational	25mA	14mA	< 400mW
Battery charging	500mA	275mA	< 7W
Sleep (no battery)	0.5mA	0.3mA	7mW
Sleep (with battery)	< 10uA	< 10uA	0.1mW

Environmental Specifications

Parameter	Specification
Storage temperature	-40 to +85 °C
Operating temperature (no battery)	-40 to +85 °C
Operating temperature (with battery)	-20 to +60 °C (note: no charging below 0°C)
Ingress Protection	IP67 (dustproof and waterproof to 1m*)
Vibration, broadband random	Complies with IEC60068-2-64
Shock	Complies with IEC60068-2-64
Humidity	Complies with IEC60068-2-64

* Conditions as per DIN VDE 0470 PART 1 / EN 60 529 / IEC 529

Configuration

The AT220 has a versatile set of features to facilitate detailed customisation.

Programming with an ASCII Terminal

Custom configuration of the AT220 is best achieved via a serial interface to a PC. It is possible to use any ASCII terminal program (e.g. HyperTerminal, Teraterm, ProComm, Com7 etc.) to enter commands. Terminal settings are 115200 baud, 8 data bits, 1 stop bit, no parity and no flow control.

How to Start a HyperTerminal Session (Windows Vista and earlier)

To open a HyperTerminal session, go to the Windows Start Menu and select:

Start – Programs – Accessories – Communications – HyperTerminal

Double click on the Hypertrm.exe icon and enter a name for the session (e.g. AT220 Terminal). Select "Direct to COM1" (or whatever COM port you are using) from the bottom field of the "Connect To" dialogue box. Now select "115200" bits per second and "None" for Flow Control. Select OK and the terminal session will start. Note that the AT220 does not echo typed characters, so it is also useful to enable the "echo typed characters locally" option from the Properties – Settings – ASCII Setup menu. These settings can be saved by selecting the appropriate option before closing the session.

Terminal Program for Windows 7

Windows 7 does not include HyperTerminal. In this case we recommend Teraterm, which can be downloaded free of charge.

Command Format

The AT220 uses the same command format for all input methods; TCP, SMS and RS232.

Each command will take the following format:

```
$AAAA, <arg1> , <arg2> , <argX><CR><LF>
```

Where AAAA is the command code and the text enclosed in < > are optional arguments.

Response Format

Each command will result in one response, by the same mode as the command was received. For multiple commands see the section Multiple Command Response Format.

The format of an individual response message is as follows:

```
$AAAA, <status><CR><LF>
```

Where <status> is one of the following values

UN	Unknown Command
OK	Command Completed Successfully
ER	Command Failed (Error)
PR	Password Required

Single Command Examples

Status	Command	Response	
Unknown	\$FISH, 400 , 56	\$FISH, UN<CR><LF>	unrecognised command
Success	\$DIST, 50	\$DIST, OK<CR><LF>	valid command, ok
Error	\$DIST, 9999909090	\$DIST, ER<CR><LF>	parameter out of range

Multiple Command Format

In SMS/TCP/UDP modes it is often convenient to send several commands together in one SMS or packet. It is possible to append multiple commands together as described below.

Example1

```
$DIST,50<CR><LF>  
$GPSQ,100<CR><LF>
```

Example2

```
$DIST,500$APPW,orangeinternet$FRED,1
```

Multiple Command Response Format

Multiple commands received at the same time via any mode will result in one response for each command parsed. The responses will be in exactly the same format as those described in the section Single Command - Response.

For Example2 above the response would be:

```
$DIST,OK<CR>$APPW,OK<CR>$FRED,UN<CR><LF>
```

The first two commands are recognised and successfully executed, whereas the last command is unrecognised.

Over the Air Configuration by SMS/GPRS

The commands and formats described above can all be used over SMS, UDP or TCP sockets. The response will always be returned by the same mode as the command is received, so commands submitted by SMS will be responded to by SMS to the sender's phone number. Note that the sender's telephone number must be disclosed for the response to succeed.

Application Parameters

GPRS Access Point Address (APAD)

When using GPRS mode, it is necessary to set the access point network (APN) details for the specific network being used. This information should be supplied by your GSM Network Operator or Service Provider. A list of GPRS access point addresses, usernames and passwords for most GSM operators can be found at <http://www.taniwha.org.uk/gprs.html>

GPRS Access Point Username (APUN)

See above.

GPRS Access Point Password (APPW)

See above.

TCP Acknowledgment Timeout (TCPT)

This parameter specifies the maximum number of seconds that the AT220 device will wait for the host to send the ACK code in response to sending a report. The default value is 30 seconds. A value of zero will disable the acknowledgment feature.

TCP Host IP Address (IPAD1)

When using GPRS mode, the host server must provide a TCP socket with a static (public) IP address. This address should be entered (without the port number). Alternatively, a hostname can be accepted for the IPAD parameter, in which case the GPRS network service provider will provide the DNS look-up to resolve the hostname to an IP address. Maximum hostname length is 64 characters.

NOTE: IP address should be entered **WITHOUT LEADING ZEROS**

TCP Host Port Number (PORT1)

The port number for the TCP host, as required for GPRS mode.

PTDM Host IP Address (IPAD2)

Host IP address or hostname to be used in Pass Through Data Mode. Maximum hostname length is 64 characters. Please refer to the appropriate Application Note for further details.

NOTE: IP address should be entered **WITHOUT LEADING ZEROS**

PTDM Host Port Number (PORT2)

Port number to be used in Pass Through Data Mode. Please refer to the appropriate Application Note for further details.

Communication Mode (MODE)

This command specifies the required GSM communication mode, as described in the table below:

<mode>	Communication method
1	RESERVED
2	RESERVED
3	RESERVED
4	GPRS (TCP)
5	GPRS (UDP)

Reporting Level (REPL)

This parameter is a bitfield (3 bytes) which can be used to enable/disable certain types of report based on their reason code. The bits are defined to match the reason bytes in the appropriate protocol, set the appropriate bit to enable reports based on the associated reason. Note there are differences between protocols, please refer to specific protocol documentation for details.

A value of 16777215 will enable all reports.

Reporting Protocol (PROT)

The AT220 supports various reporting protocols (data packet formats). For compatibility with existing systems, protocols "A", "C" and "F" are available (as per our AT100). To take advantage of the full AT220 feature set, the specific AT220 protocol "K" is recommended. Documentation for each is available on request from Astra Telematics, please email support@gps-telematics.co.uk for a copy. Protocol "L" is used for CANBus reporting.

<prot>	Reporting protocol
0	Fixed packet protocol "A"
1	Fixed packet protocol "C"
2	Fixed packet protocol "G" Basic version
3	Fixed packet protocol "G" Extra version
4	Fixed packet protocol "H"
5	Fixed packet protocol "F"
6	Fixed packet protocol "K"
7	Fixed packet protocol "L"

Pass Through Data Mode (PTDM)

Pass through data mode enable. Set this parameter to 1 to enable Pass Through Data Mode. Note that when Pass Through Data Mode is enabled, debug and NMEA output are suppressed from the AT220 serial port (DBUG and NMEA set to zero). Please refer to the appropriate Application Note for further details.

SMS Server Phone Number (SERV)

This is the delivery destination for SMS position reports. The SMS reports are typically sent to a GSM modem, which is connected to a PC and GIS server application. In this case, the server number should be that of the modem connected to the GIS server. The number should be entered in international format (e.g. +447979123456). If your application is configured to use GPRS mode and you do not require a fallback to SMS mode, the Server Phone Number should be set to "NONE".

Alarm Phone Number (ALRM)

This is the delivery destination for alarm text messages sent via SMS. These are typically sent to a GSM handset (mobile telephone). The number should be entered in international format (e.g. +447979123456). Alarm text messages are sent for panic button activation, power status events, towing alarm and low battery events.

SMSC Number (SMSC)

Each GSM network has a unique number for receiving SMS messages into the network switching centre. This unique number is known as the SMS centre or SMSC number. If the SMSC number is stored on the SIM card, it will not be necessary to enter this parameter, as the AT220 will read the number from the SIM. If the SMSC number is not available on the SIM, the correct number must be entered into the AT220 before SMS messages can be sent via the GSM network. If you do not know the correct SMSC number, your GSM network support staff should be able to advise (otherwise, please contact Astra Telematics for advice). The SMSC number need never again be changed (unless you change the SIM card to a new network operator), even when roaming on other GSM networks.

Note: in almost all cases, it is not necessary to enter an SMSC number

Roaming Enable (ROAM)

This parameter can be used to disable network roaming, as a means of controlling GSM network running costs. A value of zero will disable network roaming. The ROAM parameter can also be used to allow reporting at a reduced rate when roaming. A value of greater than 1 will cause the reporting intervals (DIST, HEAD, STIM and JTIM) to be extended by the specified value of ROAM. For example, when ROAM is set to 2, all of the reporting intervals are doubled, so that the reporting rate will be approximately half as much as when using the home GSM network operator. The default setting for ROAM is 1, which enables normal reporting on either home or roaming networks.

SMS Monthly Usage Limit (SMSL)

This parameter can be used to control SMS costs by setting a monthly limit on the number of SMS which may be sent from the AT220. A value of zero will disable the Monthly SMS Limit feature.

Distance Reporting Interval (DIST)

Distance based reporting interval in metres. This feature can be disabled by setting Minimum Distance Moved to zero.

Heading Reporting Threshold (HEAD)

The objective of this feature is to provide a vehicle trace which closely follows the actual route, but with the minimum of position update reports. In broad terms, the system provides fewer updates whilst driving in a straight line (e.g. motorways), but increases the number of updates whilst negotiating corners (e.g. city/town driving). Heading based reporting can be disabled, by setting HEAD to zero.

Stationary Timed Message Interval (STIM)

This parameter defines the maximum time interval between position update reports whilst stationary. The appropriate value for Stationary Timed Interval will depend on the user application. A typical value is 60 minutes. Setting the Stationary Timed Message Interval to zero will disable time based reports whilst stationary.

Journey Timed Message Interval (JTIM)

This parameter defines the maximum time interval between position update reports whilst in a journey. A journey is defined by GPS (i.e. when moving) when IGMN is set to zero or by the IGNITION SENSE input when IGMN is set to 1. The appropriate value for Journey Timed Interval will depend on the user application. This reporting mode is disabled in the factory setting, because most applications require only distance and heading based reports whilst in a journey. Setting the Journey Timed Message Interval to zero will disable time based journey reports.

Idle Mode Timed Message Interval (ITIM)

This parameter defines the maximum time interval between position update reports when a vehicle is idling. Idling mode is initiated after a period of stationary time (see IDLE parameter) whilst the ignition is on. Setting the Idle Mode Timed Message Interval to zero will disable time based idle mode journey reports.

Idle Mode Threshold (IDLE)

A vehicle is defined as being in Idle Mode when a vehicle is stationary for a specific length of time whilst the ignition is on. Idle Mode ends once the vehicle starts moving again. This parameter defines the length of time (in seconds) that a vehicle must be stationary before Idle Mode is initiated. Note that Idle mode start reports, timed reports and end reports are sent to the host application, hence an excessively low value for IDLE can result in increased reporting. The default value for IDLE is 180 seconds.

Over-speed Speed Threshold (OSST)

The AT220 can be configured to report over-speed events, which are defined as exceeding a given speed for a given amount of time. The OSST parameter defines the over-speed threshold in kmh. In order to trigger an over-speed event, the vehicle must travel in excess of OSST kmh for a period of OSHT seconds (see below). Further over-speed events cannot be triggered until OSIT seconds have elapsed and vehicle speed has fallen below the OSST threshold. A value of zero for OSST will disable over-speed events/reports.

Over-speed Hold Time (OSHT)

Defines the period of time (in seconds) that a vehicle must exceed OSST kmh to trigger an over-speed event.

Over-speed Inhibit Time (OSIT)

Defines the minimum time between over-speed events. Once an over-speed event has occurred, further over-speed events cannot be triggered until OSIT seconds have elapsed.

Ignition Mode (IGNM)

This parameter defines the function of the IGNITION input and the method of journey START/STOP detection, as follows:

IGNM	Start/Stop Reports	Power Down?	Ignition Sense Input
0	based on GPS (speed)	NO	Not required
1	based on Digital 1 input	NO	GREEN WIRE
2	based on Digital 1 input	YES	GREEN WIRE
3	based on External Voltage	NO	Not required
4	based on Digital 2 input	NO	WHITE WIRE

When IGMM=3 the AT220 will detect that the vehicle engine is running from the increase in external voltage (typically, the vehicle battery voltage increases by 2 Volts whilst the engine is running. This mode requires a two wire installation and frees up a digital input for other uses. When using this mode, the AT220 must be installed with the ignition (green wire of M12 cable) disconnected or used as a digital output (low-side load switch).

Note 1: Damage can occur if a voltage source is connected to the IGNITION input when IGMM is set to 3

Note 2: please refer to the AT220 Installation Guide for installation and calibration guidance relating to the use of IGMM mode 3.

STOP Report Delay (STPD)

When IGMM is set to zero (see above), the AT220 will determine journey START and STOP events from GPS. A STOP event will occur after the vehicle has remained stationary for a pre-determined time. The length of stationary time necessary to trigger a STOP report is dictated by the STPD parameter.

GPS Minimum Acceptable Quality (GPSQ)

Defines the minimum acceptable quality threshold for an acceptable GPS fix, based on the estimated GPS position accuracy. The value for GPSQ is a percentage, allowed values are from 1 to 100. The default value is 50%, which corresponds to an estimated position error of 50m. A value of 100% specifies near perfect GPS results with an estimated error of 2m or less. A value of 1% for GPSQ specifies the lowest acceptable quality, based on an estimated error of 100m.

The AT220 GPS quality algorithms will not accept 2D fixes.

GSM Cell ID Mode (CLID)

Set the level of GSM Cell ID reporting

- 0: Never report Cell ID information
- 1: Report Cell ID information only when no GPS fix
- 2: Report GSM Cell ID information always

iButton Mode (IBTN)

Enable iButton features and configure timeouts.

\$IBTN,<ibutton_mode>,<validity_timeout_secs>,<auth_timeout_secs>

where:

<ibutton_mode> see table below
<validity_timeout_secs> ibutton validity timeout. ibutton data will be attached to all journey START and STOP reports until validity expires
<auth_timeout_secs> ibutton authentication timeout. For use in iButton modes 2 and 3
In these modes, ibutton must be presented before the vehicle engine is started. If no ibutton was seen for *auth_timeout_secs* the AT220 output switch will be closed to activate the reminder (buzzer or indicator light etc.)

IBTN	iButton enabled	Reminder	Confirm	Report all iButtons	Immobilise
0	No	N/A	N/A	N/A	No
1	Yes	No	No	No	No
2	Yes	Yes	No	No	No
3	Yes	Yes	No	Yes	No
4	Yes	No	Yes	Yes	No
5	Yes	No	No	No	Yes

Reminder: drives an indicator when ignition is turned ON until iButton is presented

Confirm: drives an indicator (short pulse) whenever and iButton is read

Report All iButtons: triggers a report each time an iButton is presented

Immobilise: output switch is used to disable the vehicle until an iButton is presented

Debug Level (DEBUG)

Set the level of debug information which is displayed in the NMEA serial output.

- 0: Only NMEA output on serial port 1
- 1: Display errors only
- 2: Display normal diagnostic information
- 3: Display extended diagnostic information
- 4: Display maximum diagnostic information

OTA Programming PIN Code (PASS)

If the value of PASS is non-zero, over the air commands must include the correct PIN code, otherwise they will be rejected. Valid PIN codes are from 1 to 65535. Setting PASS to zero disables the PIN code. The PASS command must be the first command sent in the series of OTA commands. The PASS code can be changed OTA by submitting the correct current value, followed by the new value in a later command. Only commands which change parameters require the PIN code.

Geofences (GEOF)

Device based geofences can be configured with the GEOF command, which has 5 arguments as follows:

\$GEOF,<index>,<type>,<radius>,<latitude>,<longitude>

Field	Description	Range
<index>	geofence index	1 - 100
<type>	geofence type	0 disabled 1 alarm on entry 2 alarm on exit 3 alarm on entry & exit
<radius>	geofence radius in metres	20 - 65535
<latitude>	geofence latitude, WGS84 decimal degrees	-90.0 to +90.0
<longitude>	geofence longitude, WGS84 decimal degrees	-180.0 to +180.0

Entering the command with index argument only will echo back the existing geofence settings.

Acceleration and Deceleration Maximum Thresholds (ACMX & DCMX)

Report events can be triggered on specified thresholds of acceleration and deceleration (i.e. braking). ACMX specifies the acceleration threshold in m/s/s * 10, integer format. DCMX specifies the deceleration threshold in m/s/s * 10, integer format.

Example:

```
$ACMX,35 set accel threshold at 3.5 m/s/s  
$DCMX,45 set decel threshold at 4.5 m/s/s
```

Cornering Maximum Thresholds (ACMY & DCMY)

Report events can be triggered on specified thresholds of cornering force. ACMY and DCMY specify the cornering threshold in m/s/s * 10, integer format.

Example:

```
$ACMY,35 set cornering accel threshold at 3.5 m/s/s  
$DCMY,45 set cornering decel threshold at 4.5 m/s/s
```

Collision Event Threshold (COLN)

This parameter defines the acceleration/deceleration threshold (on any axis) to be classified as a collision event. COLN specifies the threshold in m/s/s * 10, integer format.

Device Orientation (ORTN)

This parameter defines the AT220 installation orientation in order to allow corrections to be applied to the accelerometer X/Y data to ensure data is correctly orientated with the vehicle axis. When ORTN is specified correctly (as per the table below) X data will correspond to vehicle acceleration and deceleration and Y will correspond to cornering forces (+ve Y corresponding to a left turn and -ve Y for right hand turns).

ORTN	AT220 Installation Position	Data Corrections Applied
0	unspecified	No X/Y orientation corrections applied
1	M12 connector facing to vehicle LHS	No X/Y orientation corrections applied
2	M12 connector facing to vehicle rear	X/Y swapped & X axis sign inversion
3	M12 connector facing to vehicle RHS	Both X and Y axes sign inversions
4	M12 connector facing to vehicle front	X/Y swapped & Y axis sign inversion

Utility and Engineering Commands

Delete All Geofences (GEOD)

Individual geofences can be deleted by setting <type> to zero. The GEOD command provides a convenient way of deleting all geofences.

Set Digital Output (SDIG)*

Allows setting and re-setting of digital outputs.

Examples:

```
$SDIG,1,1    switch output 1 ON  
$SDIG,1,0    switch output 1 OFF
```

Immobilise (IMOB)*

Set digital output for purposes of vehicle immobilisation, giving the option of making the activation conditional on vehicle ignition status and speed to ensure safe immobilisation.

When this command is used, the output will remain in the ON (activated) state until \$IMOB,0 is received to clear the immobilise condition. When \$IMOB is used to activate the output switch, it cannot be reset or cleared with the \$SDIG command or by presentation of an iButton etc.

If \$IMOB is used with no argument, the default mode 3 is used (conditional on ignition OFF and speed = zero).

\$IMOB,<mode>

<mode>	IMOB Conditions
0	Clear immobilisation mode and deactivate output switch (OFF)
1	Activate output switch when vehicle ignition is OFF
2	Activate output switch when vehicle is stationary
3	Activate output switch when vehicle is stationary AND ignition is OFF (DEFAULT)
4	Activate output switch immediately and unconditionally

*IMPORTANT NOTE: DO NOT ATTEMPT TO USE THE IMOB OR SDIG COMMANDS WHEN THE AT220 PIN 3 (DIGITAL 1, GREEN WIRE) IS CONNECTED TO A 12/24V IGNITION SENSE, AS THIS CAN CAUSE PERMANENT DAMAGE

Restore Factory Default Settings (FACT)

Resets all parameters to factory defaults (or client defaults) as built into the device firmware.

Position on Demand (POLL)

The AT220 will send an update report to the host server in response to a variety of user-configurable events. The POLL command can be used to request an update when there is no event to report.

Firmware Update (LOAD)

AT220 firmware can be updated over GPRS with this command. The firmware files must first be loaded onto a webserver in the correct format. Please contact Astra Telematics for support and assistance on remote firmware updates.

```
$LOAD,<host-ip-address>,<port-number>,<pathname>,<filename><CR><LF>
```

Reboot (BOOT)

Trigger a device reboot.

Firmware Version (ATSW)

Returns the device firmware version

IMEI Query (IMEI)

Returns the device IMEI

Status Check (STAT)

See Appendix

Parameter Check (PARA)

See Appendix

Position Check (POSN)

A device location can be queried from a mobile phone etc. using the POSN command. The reply will be formatted as a link to google maps, which can be viewed directly from a mobile telephone handset.

\$POSN,<map_type>,<zoom>

<map_type> 'm' = map, 'k' = satellite, 'h' = hybrid

<zoom> 1-20, 20=maximum zoom in, 1=maximum zoom out

The parameters are optional. The \$POSN command alone will give a position link with map view at zoom level 10.

Format of the POSN response:

POSN:<IMEI>

DD/MM/YYYY HR:MIN:SEC

http://maps.google.co.uk/?q=AT220@<latitude>,<longitude>&t=<map_type>&z=<zoom>

Diagnostics (DIAG)

Engineering diagnostics facilities:

\$DIAG,1 GPS reset

\$DIAG,2 Modem reset

\$DIAG,3 RESERVED

\$DIAG,4 Load defaults settings

\$DIAG,5 Ignition (mode 3) recalibrate

\$DIAG,6 check battery and ext voltage (and debug to RS232)

\$DIAG,7 recalibrate accelerometer at rest values

\$DIAG,8 RESERVED

\$DIAG,9 RESERVED

Data Pass Through, GPS (DDGP)

This command allows configuration of the on-board A2100 GPS receiver, specify the command as the argument and it will be submitted to the GPS receiver.

Data Pass Through, Modem (DDMO)

This command allows AT commands to be submitted to the on-board Sagem HiLo GSM modem, specify the command as the argument.

Erase Stored Reports (ELOG)

Erase stored reports from non-volatile (flash memory). If no argument is specified, all reported will be deleted, otherwise the specified number will be deleted (oldest first).

Non-volatile Set (NVST)

Initialise runtime and lifetime odometer. If the NVST command is submitted without parameters, both values are initialised to zero.

\$NVST,<odometer_km>,<runtime_hrs>

Disable Acknowledgment (NACK)

Suppress the response to a given command (SMS/TCP mode)

NMEA enable (NMEA)

Enable NMEA GPS output on the serial port. A value of 1 enables \$GPRMC only, a higher value enabled all NMEA sentences and zero disables all NMEA GPS output (see DBUG to enable/disable other serial output).

Serial Port Baud Rate (BAUD)

Configure the baud rate of the AT220 RS232 serial port

Display Settings (SHOW)

Display settings in readable ASCII format (not recommended for TCP/SMS, see PARA)

Send SMS (SSMS)

Send an SMS text message.

`$SSMS,<gsm_number>,<message>`

This command is intended to engineering purposes, typically to check/confirm GSM telephone number for unknown SIMs. The implementation does not provide any message buffering or communication retries etc. and hence it is not recommended for operation applications.

Status Check (STAT) – Machine Friendly Version, Protocol “C” AT100 compliant

The format of the STAT response when using protocol A and C (PROT=0 or 1), is as follows:

STATUS:	Fixed packet header
Device serial number	15 digit IMEI number
Software version number	<major>.<minor>.<minor-minor>
Date of the last GPS fix	dd/mm/yy
Time of the last GPS fix	hh:mm:ss
Latitude of the last GPS fix	Floating point – decimal degrees
Longitude of the last GPS fix	Floating point - decimal degrees
Speed of the last GPS fix	integer - kmh
Heading of the last GPS fix	Integer - degrees
External Input voltage	Floating point - volts
Battery Level Percentage	integer
Number of reports stored in flash	integer
SMS used this month/monthly limit	Integer/integer
Network Roaming	“H” for home network and “R” when roaming
GPS timeout error	0 : no error 1 : GPS timeout 2 : jammer detected
Modem GPRS attach error	Boolean (0 = no error, 1 = error)
Modem GPRS connect error	Boolean
Modem TCP socket error	Boolean
Modem TCP acknowledgment error	Boolean
Ignition input inactivity error	Boolean

Notes on error codes:

1. GPS timeout

No GPS fix has been returned for the specified timeout period (GPST). Could be an indication of an antenna fault or simply that the vehicle is parked in covered area (e.g. underground car park).

2. Modem GPRS attach fail

Can be simply due to GSM network coverage, but persistent attach failure is an indication that the GSM SIM card is not enabled for GPRS.

3. Modem GPRS connect fail

If the modem is attached, but not connected, this is usually caused by incorrect GPRS access point settings (APAD, APUN and APPW). See appendix E for a list of access point details for most networks.

4. Modem TCP socket error

The modem has failed to open a socket on the specified IP address and port number. Can be caused by incorrect TCP address settings (IPAD, PORT), a fault at the host server or even wider internet problems.

5. Modem TCP acknowledgment fail

This error code indicates that the AT100 can proceed all the way to open a socket and deliver the report packet, but does not get the normal acknowledgment response from the host TCP application. This is normally caused by a fault at the host end.

6. Ignition input inactivity error

This error is set when no ignition events have been detected for more than 24 hours

Status Check (STAT) – Machine Friendly Version, Protocol “G”

The format of the STAT response when using AT220 specific protocols (PROT>1), is as follows:

STATUS:	Fixed packet header
AT220 serial number	15 digit IMEI number (serial number of device)
Software version number	Floating point number
Date of the last GPS fix	dd/mm/yy
Time of the last GPS fix	hh:mm:ss
Latitude of the last GPS fix	Floating point – decimal degrees
Longitude of the last GPS fix	Floating point - decimal degrees
Speed of the last GPS fix	integer - kmh
Heading of the last GPS fix	Integer - degrees
External Input voltage	Floating point - volts
Battery Level Percentage	Integer %
Number of reports queued/stored	integer
SMS used this month/monthly limit	Integer/integer
Network Roaming	“H” for home network and “R” when roaming
GPS current satellites used	Integer
GPS % availability (last 7 days)	Integer %
GSM current signal strength	Integer
GSM % availability (last 7 days)	Integer %
GSM Mobile Network Code	Integer
Ignition status, current	Boolean
ERROR CODES:	
GPS timeout error	0 : no error 1 : GPS timeout 2 : jammer detected
Modem GPRS attach error	Boolean (0 = no error, 1 = error)
Modem GPRS connect error	Boolean
Modem TCP socket error	Boolean
Modem TCP acknowledgment error	Boolean
Ignition inactivity error	Boolean

Note: interpretation of error codes is identical to protocol C version, described above

Parameter Check (PARA) – Machine Friendly Version, Protocol “C” AT100 compliant

PARA:	Fixed packet header
Software version number	Floating point number
SERV SMS host number	International format telephone
IPAD primary TCP IP address	TCP IP address
PORT primary TCP port number	TCP port number - integer
IPAD2 TCP IP address for PTDM mode	TCP IP address
PORT2 TCP port number for PTDM mode	TCP port number - integer
APAD access point address	Text string
APUN access point username	Text string
APPW access point password	Text string
GPST (not supported on AT220)	Integer (fixed to zero)
DIST distance report value (metres)	Integer
HEAD heading change report value	Integer
JTIM in-journey timed reporting interval	Integer
STIM stationary timed report interval	Integer
ITIM idling timed report interval (minutes)	Integer
IDLE idle mode start threshold (seconds)	Integer
STPD stop report delay (seconds)	Integer
OSST overspeed threshold (kmh)	Integer
OSHT overspeed hold time (sec)	Integer
OSIT overspeed inhibit time (sec)	Integer
MODE GSM reporting mode	Integer
SMSL maximum monthly SMS usage	Integer
IGNM ignition mode	Integer
GPSQ minimum GPS quality	Integer
GPSS (not supported on AT220)	Integer (fixed to zero)
ROAM network roaming enable	integer
TCPT TCP mode timeout (seconds)	Integer
TCPM TCP socket mode	Integer
TEMP Temperature recorder mode	Integer
RFSC RFID Site Code	Integer
IBTN iButton Mode	Integer
PTDM pass through data mode enable	Integer
GSM network operator name	Text string (max 12 chars)
GSM own telephone number	Text string (max 15 chars)

Parameter Check (PARA) – Machine Friendly Version, Protocol G

PARA:	Fixed packet header
Software version number	Floating point number
SERV SMS host number	International format telephone
IPAD primary TCP IP address	TCP IP address
PORT primary TCP port number	TCP port number - integer
IPAD2 TCP IP address for PTDM mode	TCP IP address
PORT2 TCP port number for PTDM mode	TCP port number - integer
APAD access point address	Text string
APUN access point username	Text string
APPW access point password	Text string
DIST distance report value (metres)	Integer
HEAD heading change report value	Integer
JTIM in-journey timed reporting interval	Integer
STIM stationary timed report interval	Integer
ITIM idling timed report interval (minutes)	Integer
IDLE idle mode start threshold (seconds)	Integer
STPD stop report delay (seconds)	Integer
OSST overspeed threshold (kmh)	Integer
OSHT overspeed hold time (sec)	Integer
OSIT overspeed inhibit time (sec)	Integer
MODE GSM reporting mode	Integer
PROT reporting protocol	Integer
REPL reporting level	Integer
SMSL maximum monthly SMS usage	Integer
IGNM ignition mode	Integer
GPSQ minimum GPS quality	Integer
ROAM network roaming enable	integer
TCPT TCP mode timeout (seconds)	Integer
IBTN iButton Mode	Integer
CLID cell-ID mode	Integer
PTDM pass through data mode enable	Integer
GSM network operator name	Text string (max 12 chars)
GSM own telephone number	Text string (max 15 chars)