

Application Note: AT220 Driver ID using iButtons

Overview

The AT220 can be used with Maxim-Dallas iButtons (AKA Dallas Keys) to provide information about the driver of a given vehicle for specific journeys.

Requirements

- Rugged Vehicle Tracking Device
- M12 Power Cable, 1.0m
- iButton Probe
- iButton (keyfob mounted)

Part Number

AT220
CB221 or CB222
DS9092 / DS1402-RP8
DS1990R-F5

Hardware Configuration

The iButton probe is connected directly to the AT220 iButton input, as follows:

PROBE SIGNAL DS9092 (grey) → AT220 Pin 5 (M12 cable, grey wire)
PROBE GND DS9092 (black) → AT220 Pin 8 (M12 cable, red wire)

Please refer to the last page of this document for detailed wiring diagrams.

AT220 Configuration

The AT220 is enabled for iButton mode using the IBTN parameter. Setting the IBTN parameter to 1 tells the AT220 to expect to see iButton information. The IBTN parameter can be set in the usual way by serial, TCP or SMS command, as per the example below:

```
$IBTN,2                    // enable iButton mode with reminder buzzer
```

The iButton holds a 1 byte family code and a 6 byte serial number. This data is reported when available with each journey START and STOP report (see appropriate protocol description document, available on request from Astra Telematics)

Reminder

This AT220 output * can be used to help ensure that the driver does not forget to present the iButton on the probe for each journey. In this mode, the output is switched ON whenever the engine is running (detected from supply voltage in IGNM 3) until an iButton is presented. The iButton can be presented up to 30 seconds before starting the engine to suppress the output being activated. Whenever an iButton is presented on the probe, the output will be turned OFF, otherwise the output will remain ON until the engine is turned off. This can be used with an external audible device to ensure that the driver presents his/her iButton.

*Note that the AT220 output can only be used when IGNM=3 or 4 as the relevant pin is shared with the IGNITION input. Please refer to the IGNM parameter description in the AT220 User Guide for details.

Please see the table below for reminder options.

Immobiliser

The iButton can be used as a condition for vehicle starting, preventing use without the presentation of an iButton. In this case, an iButton must be presented before starting the vehicle.

iButton Mode (IBTN)

Enable iButton features and configure timeouts.

\$IBTN,<ibutton_mode>,<validity_timeout_secs>,<auth_timeout_secs>

where:

<ibutton_mode> see table below
<validity_timeout_secs> ibutton validity timeout. ibutton data will be attached to all journey START and STOP reports until validity expires
<auth_timeout_secs> ibutton authentication timeout. For use in iButton modes 2 and 3 In these modes, ibutton must be presented before the vehicle engine is started. If no ibutton was seen for *auth_timeout_secs* the AT220 output switch will be closed to activate the reminder (buzzer or indicator light etc.)

IBTN	iButton enabled	Reminder	Confirm	Report all iButtons	Immobilise
0	No	N/A	N/A	N/A	No
1	Yes	No	No	No	No
2	Yes	Yes	No	No	No
3	Yes	Yes	No	Yes	No
4	Yes	No	Yes	Yes	No
5	Yes	No	No	No	Yes

Reminder: drives an indicator when ignition is turned ON until iButton is presented
Confirm: drives an indicator (short pulse) whenever and iButton is read
Report All iButtons: triggers a report each time an iButton is presented
Immobilise: output switch is used to disable the vehicle until an iButton is presented

Recommended Suppliers

Homechip
15 Drayton Road
Road
Newton Longville
Milton Keynes
MK17 0BH
UK

Fairbridge Technologies
The Gatehouse

35 Robjohns Road
Chelmsford
CM1 3AG
UK

iButtonLink LLC
N8921 Stone School

East Troy
WI 53120
USA

Tel: +44 (0) 845 862 0220
info@homechip.com
www.homechip.com

Tel: +44 (0)1245 349032
uksales@fairbridgetech.com
<http://www.fairbridgetech.com>

Tel: + 1 262-662-4029
info@ibuttonlink.com
www.ibuttonlink.com

Wiring Requirements

1. iButton with Reminder Buzzer

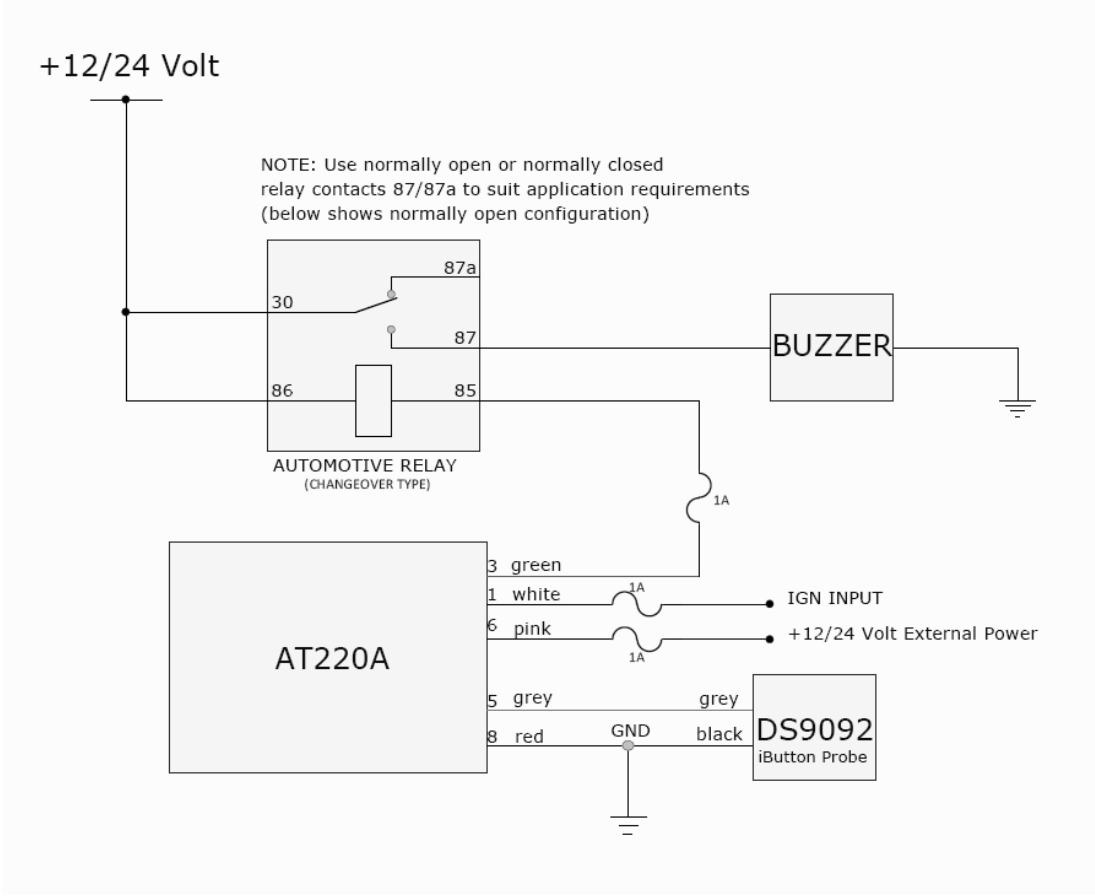

2. iButton with Immobiliser

